



BRIDGE RAILING SYSTEMS

CAST POST

3-RAIL

No. MDS-3001-A

**PEDESTAL
Side View**

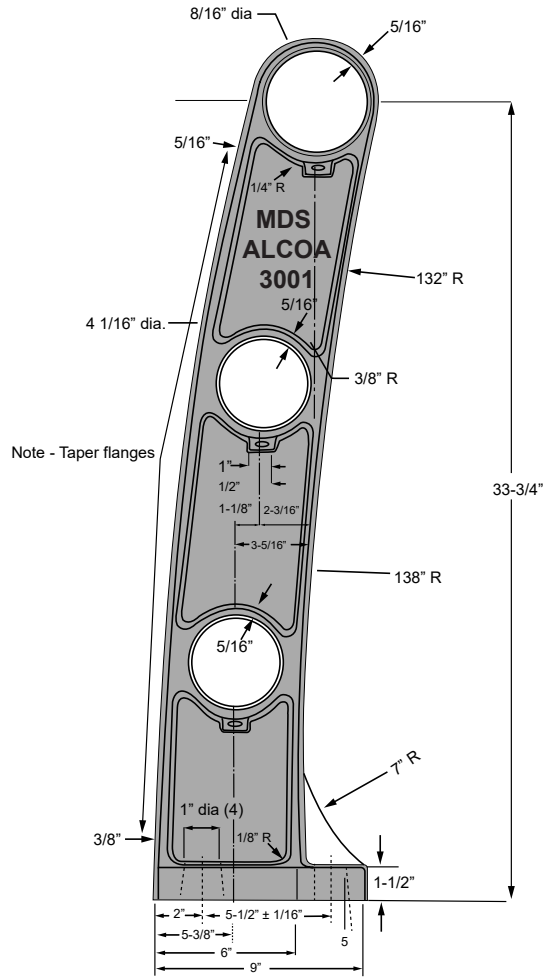

**RAIL
Back View**

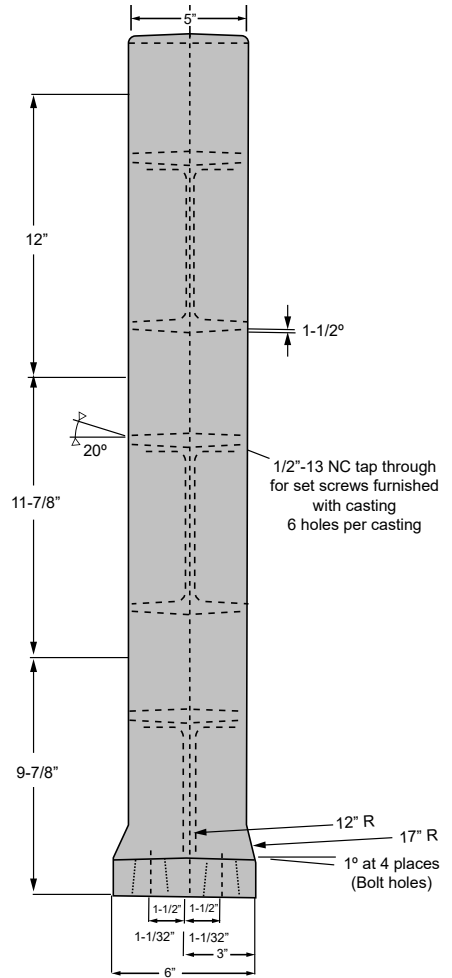

TUBE ALLOY 6061-T6

ITEM	Pcs.	Description	Size	Unit Wt.	Total Wt.
1	1	Top Rail	4-1/2" O.D. x 1/8" wall x 8'-3" long	2.02 lb/ft	16.66
2	2	Bottom Rail	4" O.D. x 3/16" wall x 8'-3" long	2.65 lb/ft	21.85
3	1	*†Post Alcoa No. 3001			35.00
				Total	73.51

Alcoa MDS-3001-A 3-Tube bridge rail & pedestal

Route 128 Canton Massachusetts
 Designed by: Department of
 Public Works, Commonwealth
 of Massachusetts

TUBE ALLOY 6061-T6

ITEM	Pcs.	Description	Size	Unit Wt.	Total Wt.
1	1	Top Rail	4-1/2" O.D. x 1/8" wall x 7'-0" long	2.02 lb/ft	14.14
2	2	Bottom Rail	4" O.D. x 3/16" wall x 7'-0" long	2.65 lb/ft	18.55
3	1	*†Post Alcoa No. 3001			35.00
				Total	67.69

